

SUPERIOR

MVP-300

MagVibe^{Pro}

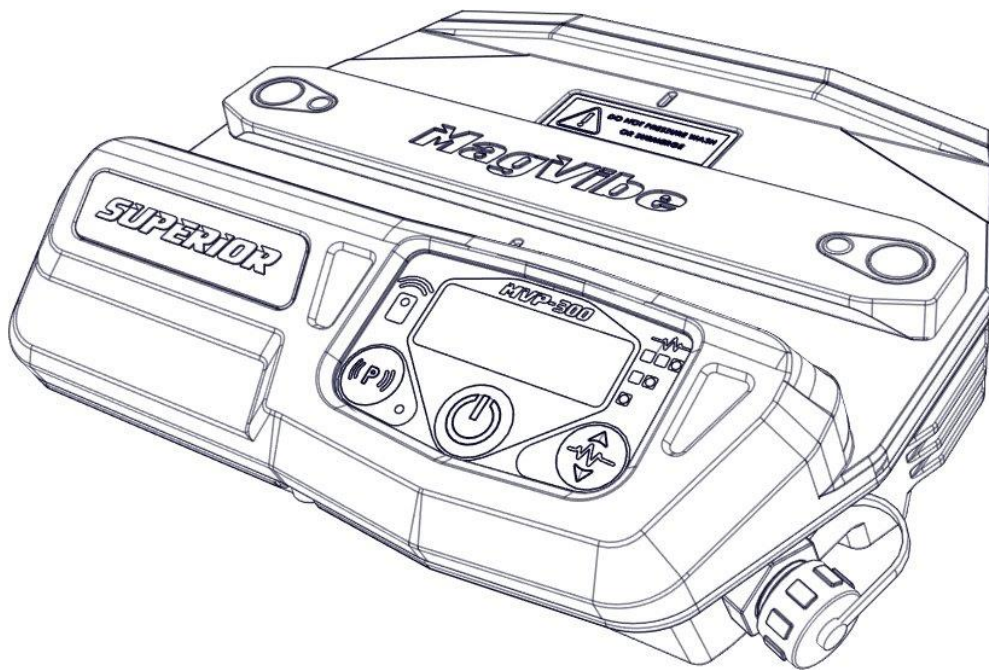

MVP 300 User Manual

P/n: D-17836

General

Safety symbols:



WARNING! If used incorrectly the machine can cause injury.



Please read the Operator's Manual thoroughly making sure you understand how to use the machine before use.



Always wear personal protective equipment (PPE) such as gloves, eye protection, hearing protection, and a hard hat. Jobsites might require certain protective equipment be used due to national and local regulations and insurance policies. Make sure you check with the jobsite foreman for requirements before work begins.

Dear Customer,

Thank you for choosing a Superior Innovation product. It is our intent to deliver the best products possible. Delivering innovative, well-built, ergonomic, efficient products is our goal to help you do the best job possible. Safety, and innovation are our cornerstone of design.

This Operator's Manual is a valuable document. Print it and make sure it is always accessible when using the machine. If you lend or sell this machine, make sure that this document is also transferred, so the new user will know how to properly use and maintain it. It is available for download at: www.superiorinnovationsinc.com/manuals

User Responsibility

It is the owner's / employer's responsibility to ensure that the operator is properly trained and has sufficient knowledge about how to use this machine safely. Supervisors and operators must read and understand the operators Manual. They must be aware of the safety instructions, limitations, proper use and maintenance. Local and national legislation may regulate the use of this machine. Find out what legislations are applicable in your location before use.

Superior Innovations Reservation

All of the information and data in this Operator's Manual was up to date at the time the Operator's Manual was sent to print. Superior Innovations research and development is continually working on product development and improvements. Therefore, we reserve the right to modify the design, appearance and features of the product without prior notice. The most current version of manuals can be found at:

www.superiorinnovationsinc.com/manuals

Vibration Warning



WARNING! Overexposure to vibration can lead to circulatory damage and or nerve damage, especially in people who have impaired circulation. Contact your doctor if you experience symptoms of overexposure to vibration. Symptoms include: numbness, loss of feeling, tingling, pricking, pain, loss of strength, and changes in skin color and condition. These conditions normally occur in the fingers, hands or wrists and can be further increased in cold temperatures.

Transportation and Storage

After work is completed, remove the MagVibe™ *Pro* and or ProTilt® from the float and thoroughly wipe down before the concrete has time to setup. **DO NOT USE A PRESSURE WASHER OR SUBMERGE IN WATER!** There are sensitive electronics and not all areas can be water tight.

Secure the equipment during transportation to avoid transport damage and accidents.

Store in a lockable area so that it is not able to be accessed by children or unauthorized persons.

Due to the lithium ion battery, the temperature cannot exceed 140°F (60°C).

Personal Protective Equipment (PPE)

You must use approved personal protective equipment (PPE) whenever you use the machine. Personal protective equipment cannot eliminate injury, but it will reduce the degree of injury if an accident does happen. Ask your dealer for help in choosing the right protective equipment.

Common Sense

It is not possible to cover every conceivable situation. Exercise care and use common sense if you get into a situation where you feel unsafe. Stop and seek expert advice by contacting Superior Innovations, Inc., a service dealer or an experienced user. Do not attempt any task that you are unsure of.

Work Area Safety

Observe your surroundings to ensure nothing can affect your control of the machine.

Observe your surroundings to ensure there is no risk of people or animals that can come into contact with the machine while in operation.

Do not use machine in bad weather, such as heavy rain, strong winds, intense cold, or heavy fog. Working in such weather is trying and can lead to difficult situations.

Ensure that the work area is sufficiently illuminated to create a safe working environment.

Make sure that there are no electrical cables routed in the working area.

Make sure that the work area is clear, clean and free of obstacles that can cause trips or spills.

Before Starting

Inspect equipment to ensure that there are no loose fasteners, cracks, leaks, or other obvious damage. If there are do not use until the problems are corrected.

Make sure that daily maintenance has been completed.

Make sure that the MagVibe™ Pro battery is fully charged.

In the Box

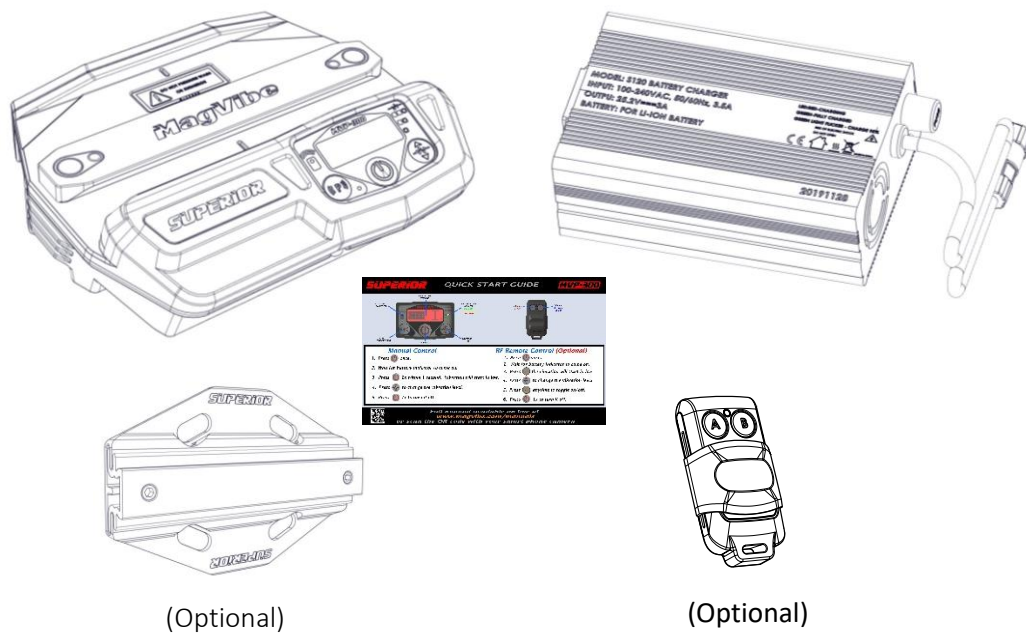

Warranty

New equipment sold by Superior Innovations is warranted to be free from manufacturing defects under normal service for a period of one (1) year from date of purchase by the original consumer. Component manufacturers offer separate warranties and are covered separately. These components are the lithium polymer battery, the electric motor, RF remote control batteries (27A) and the battery indicator. These components carry a 180-day warranty from the original date of purchase. For complete information or to request a return goods authorization number (RGA#) call technical service at (844) 624-8423.

Superior Innovation's obligation under this warranty is expressly limited to the replacement or repair at our service facility or one that has been pre-authorized by Superior Innovations.

This warranty does not apply to defects caused by damage, unreasonable use, faulty repairs made by others or defects caused by failure to provide reasonable maintenance, while in the possession of the consumer. Further, the warranty is void if the product, or any of its components, is altered or modified by the consumer or if the product is used in an inappropriate manner not recommended by the manufacturer.

The main case of the MagVibe™ is protected from opening by tamperproof fasteners and has a void if opened decal to ensure the case is not opened. If the void warranty decal is torn, removed, or damaged the warranty will be void.

In addition, a color changing water infiltration decal is located inside the MagVibe™ pro main case. If the decal changes from white to red, the warranty will also be void. This is due to use of a pressure washer or submersion in water.

Description / Features / Controls

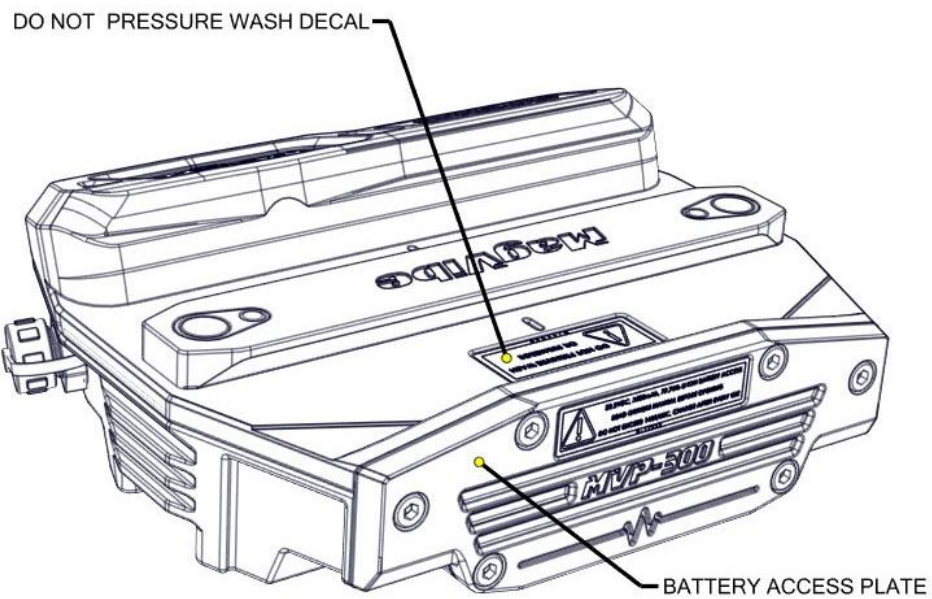
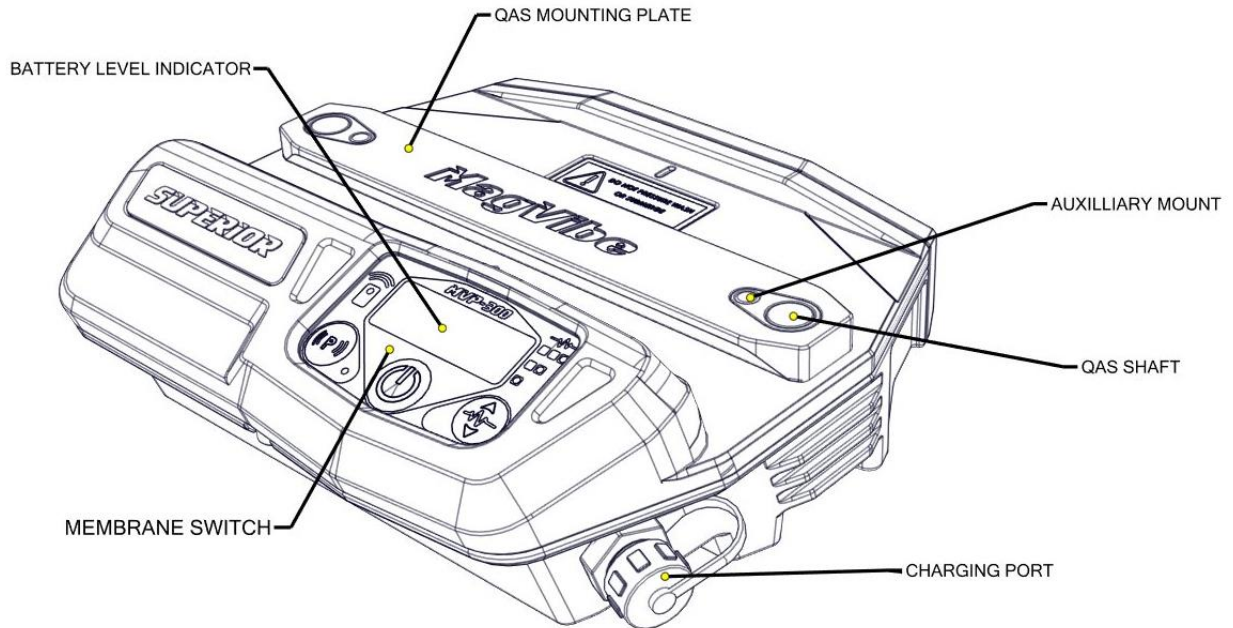

Description / Features / Controls

DO NOT OPEN CASE / VOID WARRANTY DECAL

QR CODE LINK TO MANUALS DECAL

QAS FEMALE RECEPTACLE

SERIAL PLATE

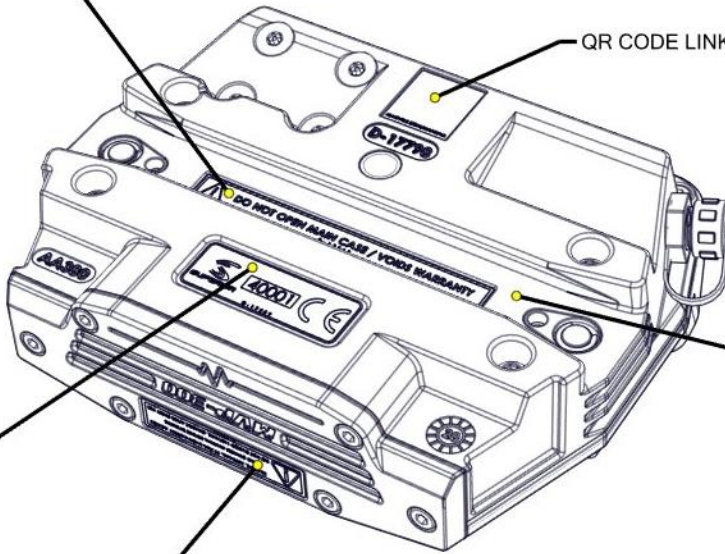

BATTERY INFORMATION DECAL

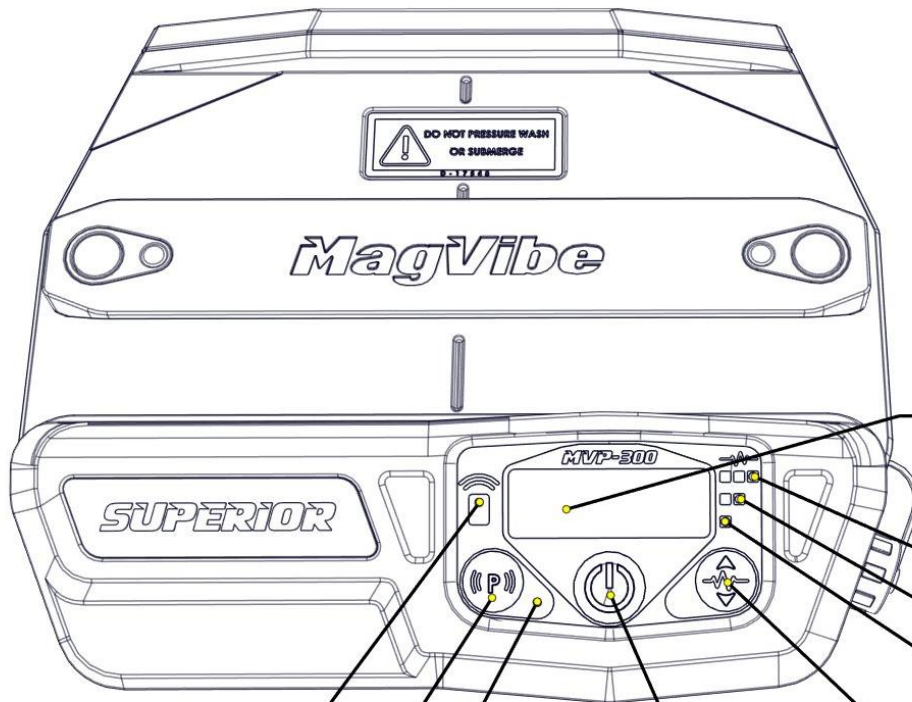

BATTERY % INDICATOR LCD DISPLAY

VIBRATION LEVEL (HIGH) LED

VIBRATION LEVEL (MEDIUM) LED

VIBRATION LEVEL (LOW) LED

RF REMOTE STATUS LED

RF REMOTE PROGRAM BUTTON

POWER / REMOTE & MANUAL OPERATION TOGGLE

RF REMOTE PROGRAM STATUS LED

VIBRATION POWER LEVEL SELECTION BUTTON

QAS

QUICK ATTACH SYSTEM

QAS™ is a quick attach system designed to make it quick and easy to attach a MagVibe™ Pro, ProTilt®, or accessories to a ProFloat™®, other Superior tools and even other manufacturers floats. The ability to quickly Remove the pivot allows for stacking of floats for transportation, easier cleanup and the ability to switch floats or other tools very fast. The MagVibe™ Pro, ProTilt® and ProFloat™® have a built-in QAS™ mounts. For other types of floats there are a variety of QAS™ adapters: The QAS™-M is a four-bolt adapter, the QAS™-W is a t-washer adapter for channel mount floats. There is also a QAS™-F adapter that converts a standard four-bolt pivot to have a quick attach system so you can attach to a ProFloat™®.

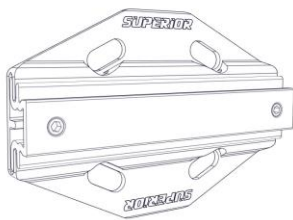

QAS™-M Adapter

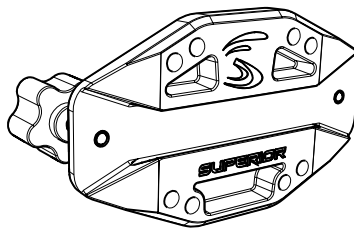

QAS™-F Adapter

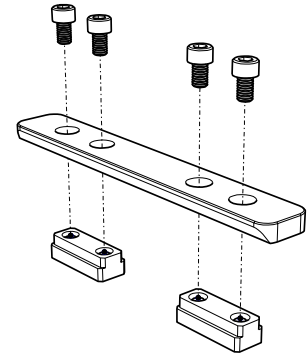

QAS™-W Adapter

MagVibe™ MVP 300 attachment to a ProTilt

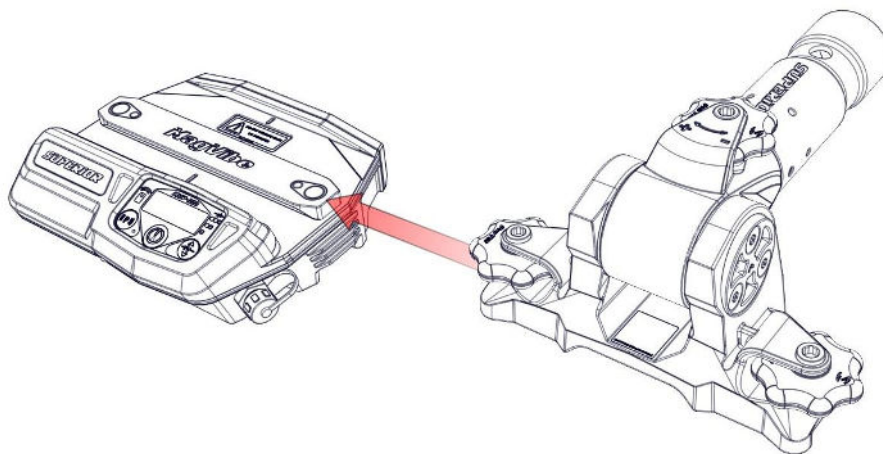

Make sure QAS knobs are loosened and the shaft is all of the way up.

Slide ProTilt onto the QAS male mount located on the top of the MagVibe™ MVP 300.

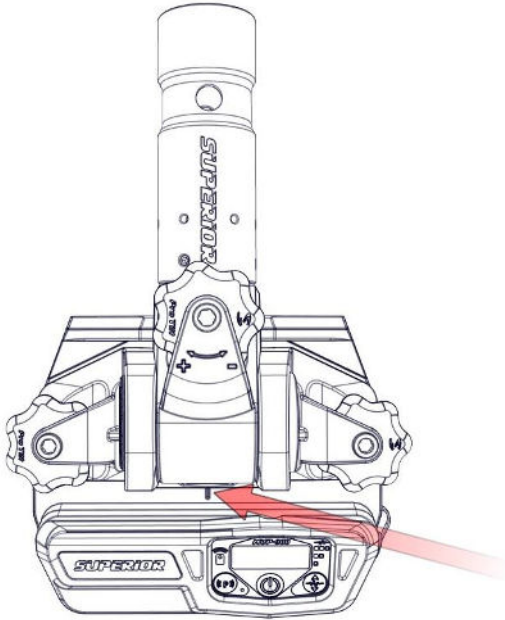

Align the center of the ProTilt with the center mark on the MagVibe™ as shown. This will help align the QAS knob shafts with the MagVibe™ shaft extensions.

Slightly tighten the QAS knobs to where the QAS shaft engages with the MagVibe™ shaft extensions.

Now you are ready to slide the system onto the ProFloat™ or other tools.

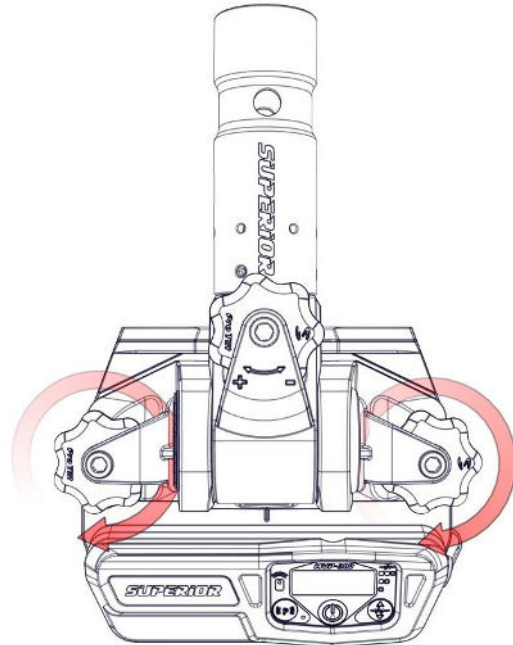

To permanently attach your ProTilt to the MagVibe™ you can now tighten the two M6 set screws up against the ProTilt base using a 3mm Allen key.

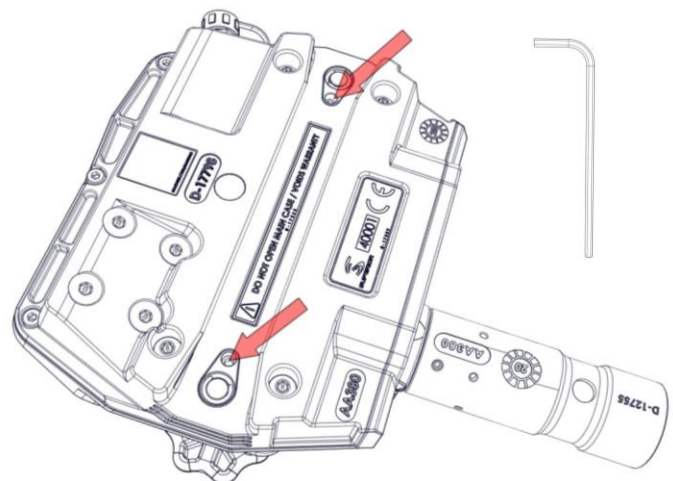

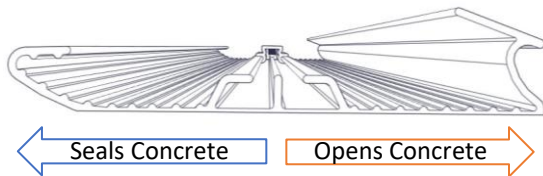
ProFloat™ Attachment

Decide which direction you want to mount the ProFloat™. We recommend that the cutting edge be facing the operator when cutting high spots and filling low spots. Once this is done the ProFloat™ can be quickly rotated 180° to open the concrete on the way out, and seal on the way back.

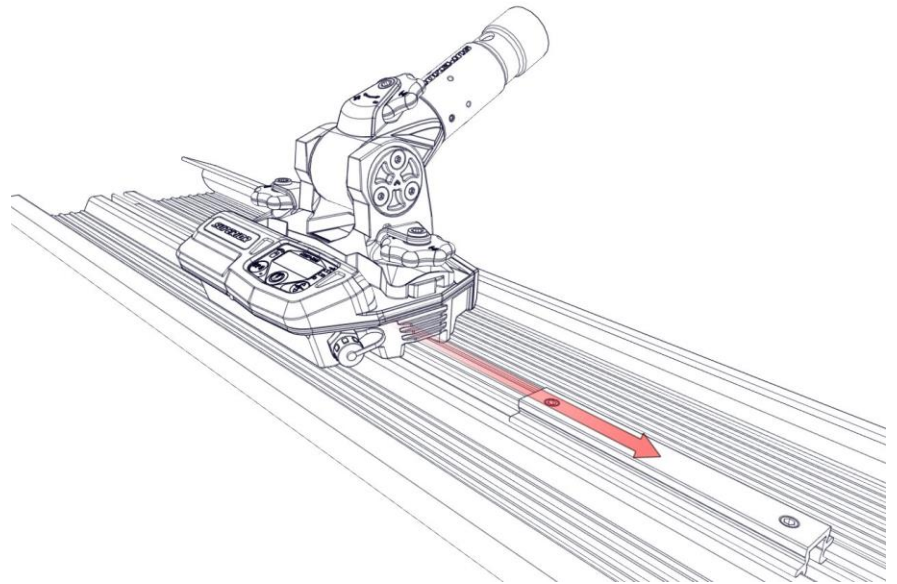

Loosen both QAS™ knobs by turning them counter-clockwise.

Align the QAS™ receptacle with the QAS™ dovetail and slide over to engage.

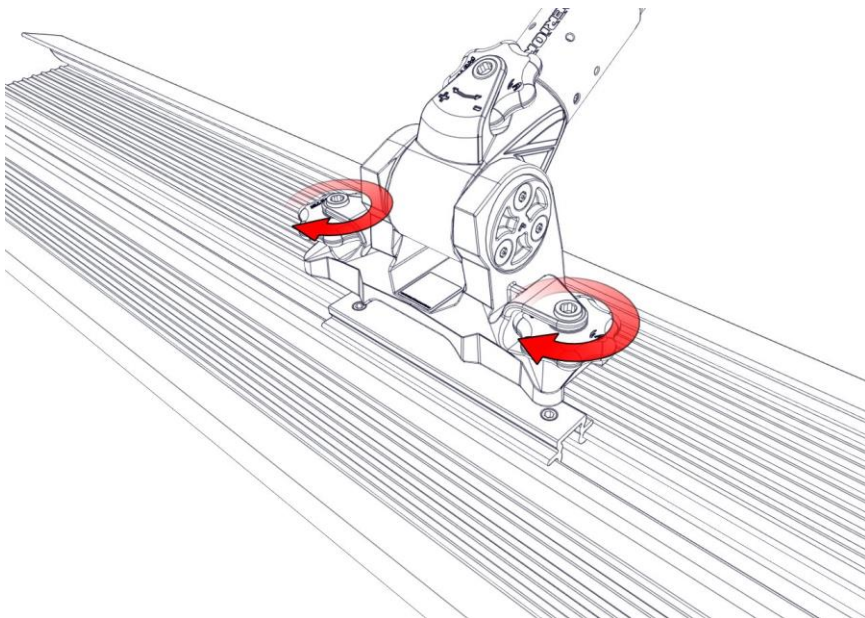

Center the MagVibe Pro™ over the QAS™ dovetail and tighten both QAS™ knobs by turning them clockwise. **DO NOT OVERTIGHTEN.**

Attaching the Pole Extension

Press and hold the pins in pole extension, then align and insert into MagVibe™ Pro pivot handle. Push into bore and make sure that the pins snap through the two holes in the pivot handle to engage.

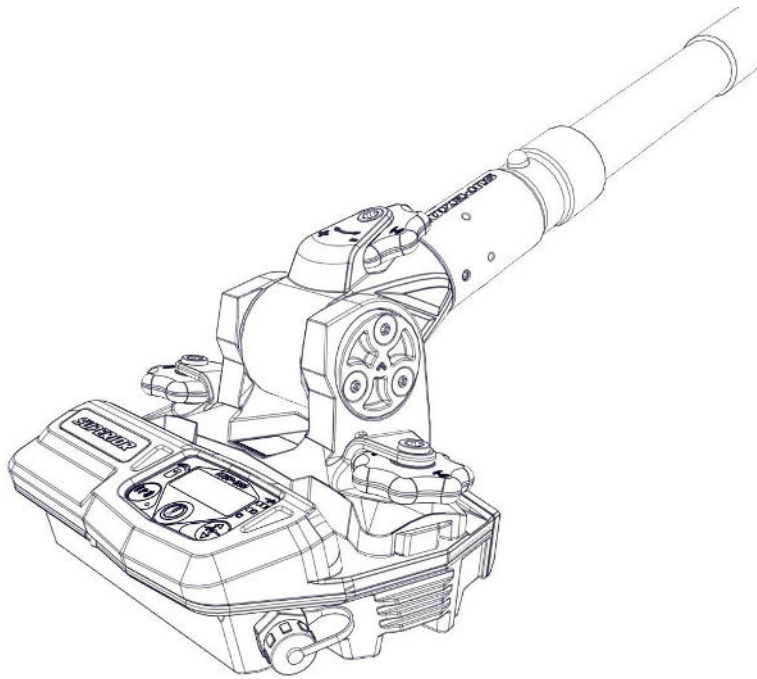
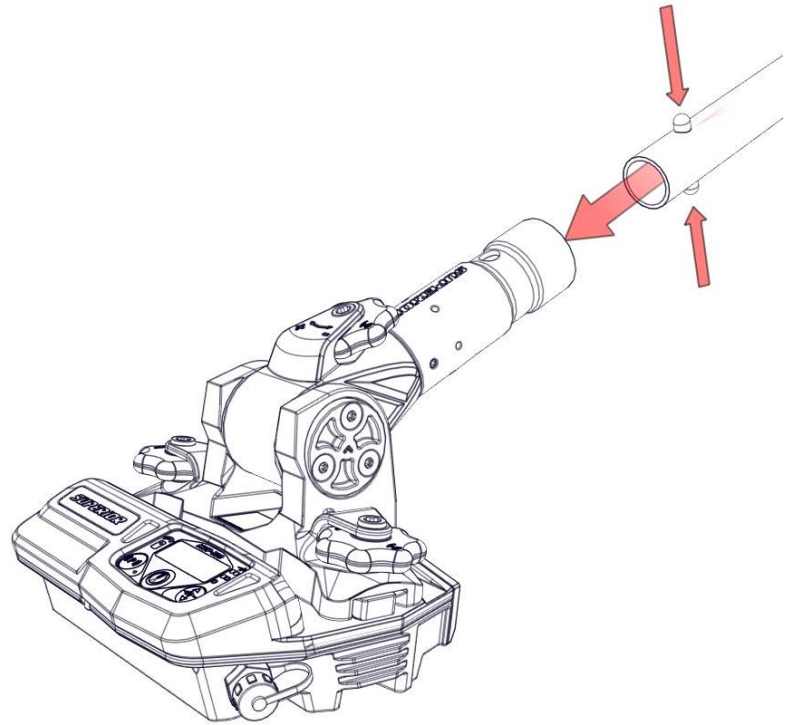

Same procedure for an outside pole extension; except you will slide the pole extension over the pivot handle. The MagVibe™ Pro pivot handle will accommodate $\text{Ø}1\text{-}3/8''$ internal and $\text{Ø}1\text{-}3/4''$ external poles.

Turning MagVibe™ Pro On / Off (RF - Remote control Mode)

There are two ways to turn the MagVibe™ Pro on and off. The first method is to use the pre-programmed RF remote control (*Optional*) and the second is to manually control the MagVibe utilizing the membrane switch. The following will walk through the controls.

To use the RF remote control, slide the protective button cover downward to expose the buttons. There are two buttons: Button A turns the MagVibe™ Pro on and off, and Button B is an auxiliary RF control for powered accessories from Superior Innovations.

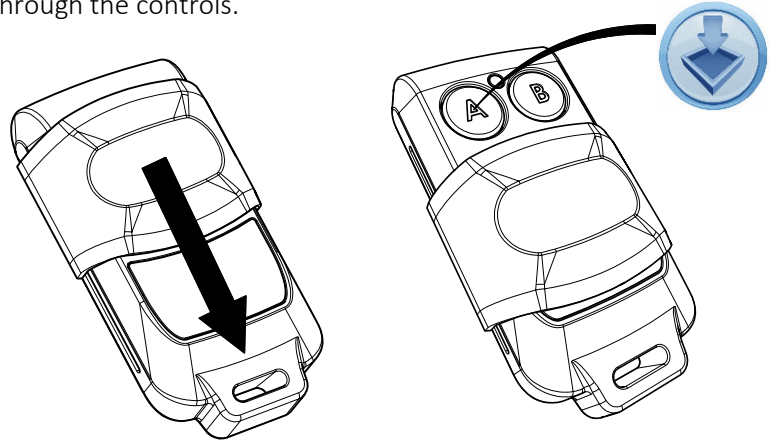

To turn the MagVibe™ Pro on and off with the remote: Press the power button on the membrane switch to wake the MagVibe.

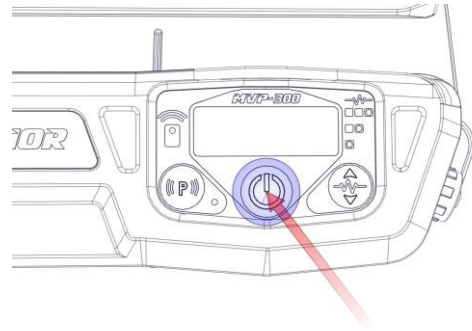

When the MagVibe is ready both the blue LED located in the remote-control icon and the green LED located in low vibration mode will light. The MagVibe is now ready to receive RF remote signals.

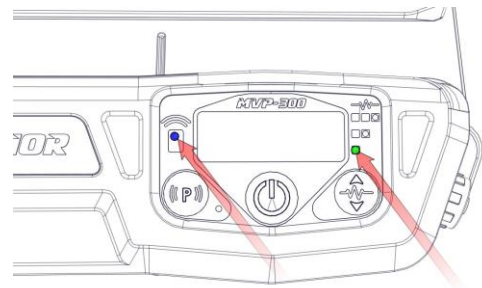

To turn on, simply press button A and the vibration will start. When you want to turn it off, press button A again.

The vibration will start in low level. To change the vibration intensity, press the vibration power level selection button to toggle between the three levels of intensity. Pressing the vibration selector button once will increase the vibration 12% and the orange LED will light.

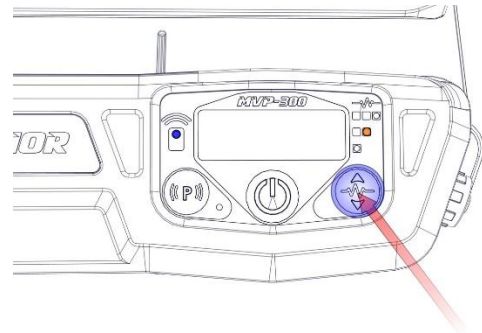

If the vibration selection button is pressed again, the vibration will increase by an additional 21% and the red LED will light. If the vibration selector button is pressed again, the vibration will return to low mode.

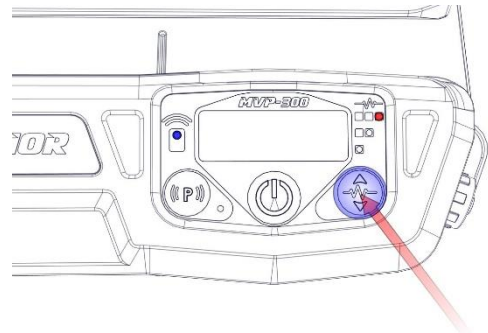

The remote-control range will depend on surroundings; however, it should have a twenty five-foot line of sight range.

Note: Since you can accidentally leave the MagVibe on while in remote mode and subsequently drain the battery, the MagVibe will go into sleep mode after 6 hours of operation (standby).

To put the MagVibe back into sleep mode, press the power button on the membrane switch once and all lights will go off as a confirmation.

Turning MagVibe™ Pro On / Off (Manual Control)

To turn the MagVibe on manually with the membrane switch, press the power button twice within a couple of seconds. The MagVibe will start vibrating in low vibration mode and the green LED will light.

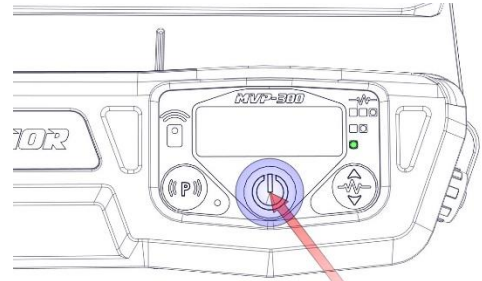

To change the vibration intensity, press the vibration power level selection button to toggle between the three levels of intensity. Pressing the vibration selector button once will increase the vibration 12% and the orange LED will light.

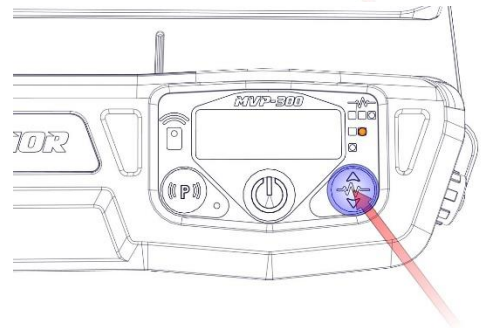

If the vibration selection button is pressed again, the vibration will increase by an additional 21% and the red LED will light. If the vibration selector button is pressed again, the vibration will return to low mode.

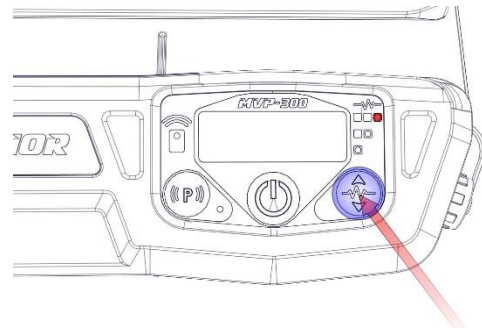

Turning the MagVibe Off

To put the MagVibe back into sleep mode, press the power button on the membrane switch once and all lights will go off as a confirmation.

Battery Indicator

The battery indicator is positioned underneath the membrane switch's clear lens so the operator can see the status of the battery when the MagVibe™ Pro is in operation. The battery status is converted into percent remaining.

We have built in an offset of the scale to protect the battery from getting too low to properly charge (20%). So, you may notice that your battery indicator displays 0%, but your MagVibe still works. At this point, you should stop the MagVibe and charge it fully. This will keep the battery conditioned to accept a full charge.

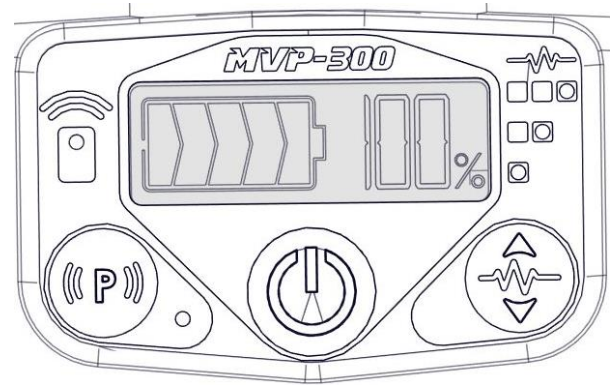

Never charge your battery inside a car. The extreme temperatures can cause a charging battery to explode.

For additional battery information please see document: 6S1P222V35AH (D-17556). This technical document can be found at www.superiorinnovations.com/manuals.

Charging the Battery

The 22.2VDC Lithium Ion battery that is built in to the MagVibe™ Pro has 3500mAh capacity which should yield ~18hrs on a single charge.

To re-charge; follow these steps:

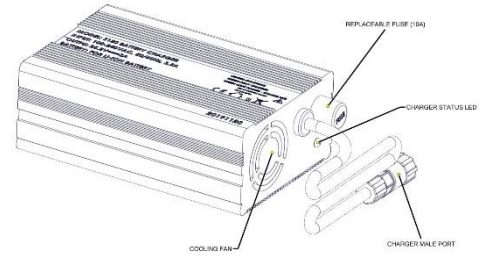

1. Unscrew the charger port canteen seal cap to expose the charger port.

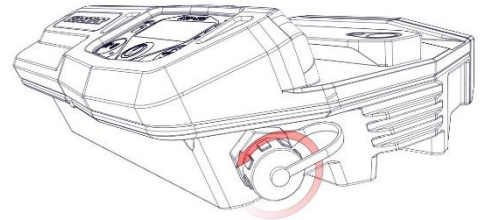

2. Line up the charger port plug and the indexer on the MagVibe charger port; push it in and tighten the retaining screw for a good connection.

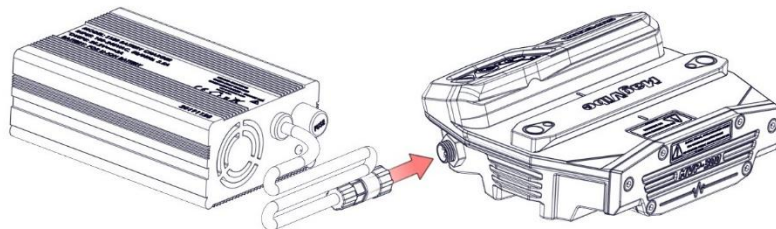
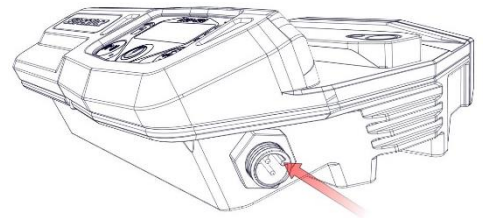

3. Plug the LiPo balancing charger (supplied) into a 120 VAC wall outlet.

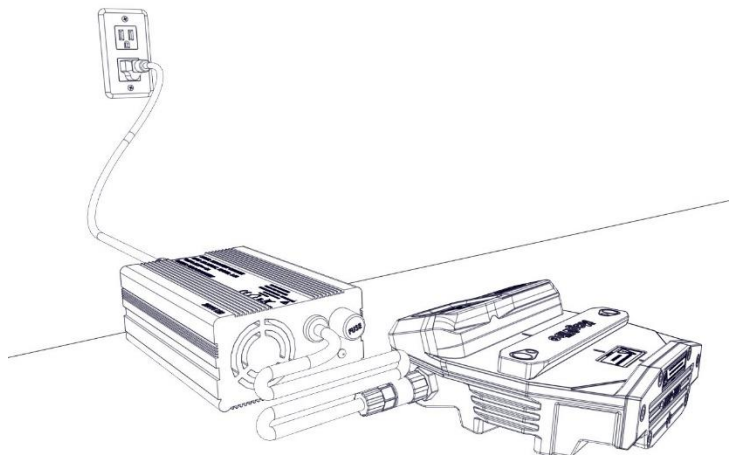

4. The LED on the side face of the charger will turn red when charging. When the battery is at 95% of full charge the LED will flash red/green. When the battery is fully charged, the LED will turn green.

Programming the Remote

If you ordered your MagVibe without a remote and want to add one or you lost your remote and need to program a replacement, you can do it yourself. You will need to order part number D-13535. Once you receive your replacement remote have it ready by sliding down the button cover to expose the two pushbuttons.

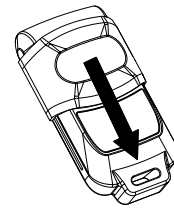

Follow these steps to program the MagVibe pro for the RF remote control.

1. Press the power button on the MagVibe to wake it up.
2. Press and hold the “P” button until the blue LED light flashes (~5 seconds). Then let go of the “P” button and wait for the blue LED to stop flashing. This clears any previously stored RF smart codes in the MagVibe.

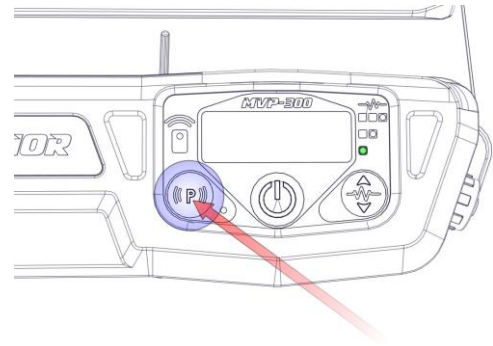
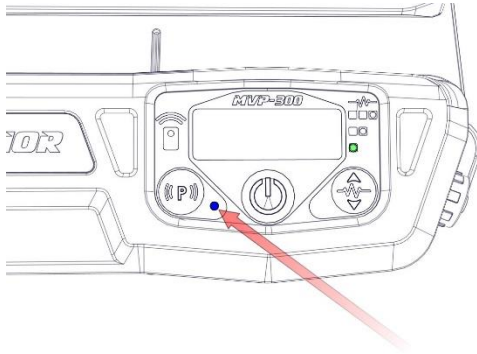

3. Press the “P” button on the membrane switch again and the blue LED will light. At this point the MagVibe is ready to read the smart scan code from the RF remote.
4. Push button “A” on the RF remote and let go. The blue LED should begin to blink.
5. Push button “A” on the RF remote again and the blue LED should go off.
6. Push button “A” again and the MagVibe will begin to vibrate if a successful pairing has taken place. If it did not turn on repeat from step 3.

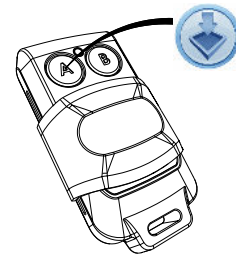

Maintenance Statement

The owner is responsible for the performance of all required maintenance, as described in the Operator’s Manual.

Maintenance Schedule

Daily Maintenance	Weekly Maintenance	Monthly Maintenance
Cleaning (external)	Cleaning (external)	Cleaning (external)
Inspection	Inspection	Inspection
loose fasteners, cracks, leaks, or other obvious damage	loose fasteners, cracks, leaks, or other obvious damage	loose fasteners, cracks, leaks, or other obvious damage
Check battery is charged and ready to go.	Check battery is charged and ready to go.	Check battery is charged and ready to go.

Maintenance

Remove MagVibe™ Pro from the float and clean after every use. Make sure to pay special attention to the QAS™ receptacle. If concrete sets-up around the QAS™ it may become difficult to use. The MagVibe™ Pro has sensitive electronics located inside the pivot and the main body; **DO NOT USE A PRESSURE WASHER OR SUBMERGE IN WATER.**

The MagVibe MVP300 has a color changing water infiltration decal inside that will only activate if the MagVibe has been cleaned with a pressure washer or submerged in water. **The presence of water in the MagVibe will void any warranty.**

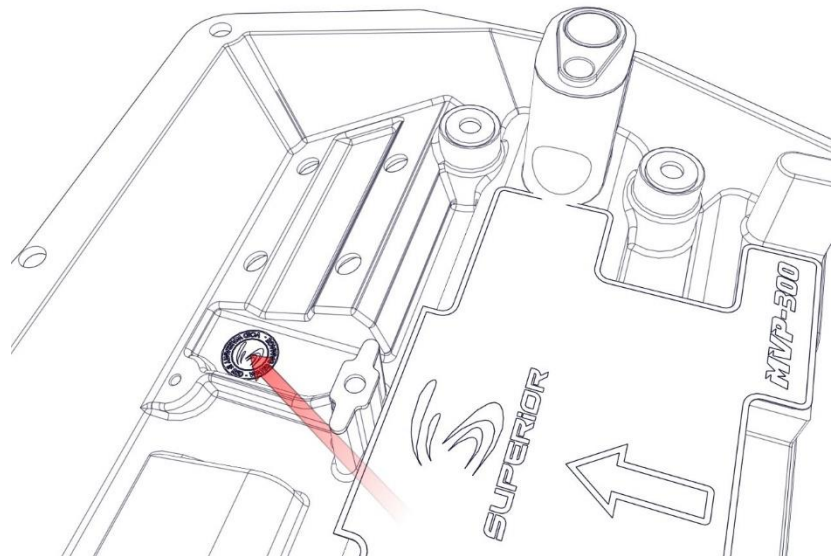

Do not attempt to access the internal components of the MagVibe; this will **void your warranty**. In addition to tamper-resistant main case fasteners, the MagVibe has a Void Warranty if Seal is Broken decal. You are able to replace the battery if ever needed. See technical document: www.superiorinnovations.com

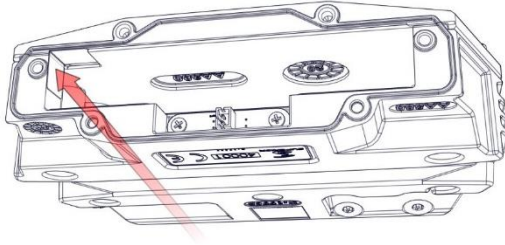

RF Remote Battery Replacement

To replace the battery in the RF remote controller, remove (4) screws on the back side of the RF remote control cover using a Philips screwdriver.

Remove the RF remote back cover plate.

Make note of the battery polarity.

Remove the RF controller board.

Remove the battery.

Install a new battery. **MAKE SURE THAT THE POLARITY IS CORRECT.**

Reinstall the RF controller board.

Place the RF remote back cover plate making sure to align the screw holes.

Reinstall the (4) screws and tighten using a Philips screwdriver. You may need to reprogram MagVibe™ Pro RF receiver if the code was lost during the battery reinstall process. See Programming a Lost Remote in this manual for instructions.

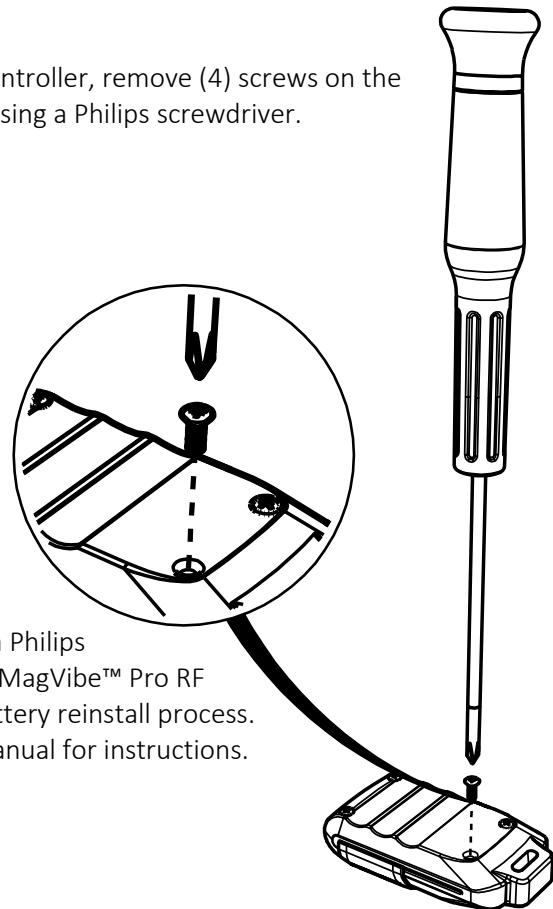

Technical Data

Dimensions		L	W	H
	MagVibe	5.69 (144.7mm)	6.59 (167.5mm)	2.82 (71.7mm)
	MagVibe and ProTilt	10.50 (267.7mm)	7.22 (183.49mm)	5.03 (127.70mm)
Mass	MagVibe	2.83# (1.27Kg)		
	MagVibe and ProTilt	5.62# (2.55Kg)		
Battery	22.2VDC, 3500mAh LiPo Battery, 6 Cell			
Motor	24V DC, 0.6A			
Runtime	~18Hr.			
Charging port	Sealed Canteen-Style			
Controls	Membrane Switch with Integrated Timer and 3 speeds			
RF Remote Controlled (Optional)	433.92MHz			
Antenna	Integrated PCB antenna (Internal)			
Mounting / Attachment	Quick Attach System (QAS) integrated in MVP and ProTilt			
Tilt Angle ProTilt G3	210°			
Gearbox	Fully Sealed			
Bearings	Sealed Ball Bearings			
Tensioner	Fine control and pivot Stop			
Pole Extension Attachment	1-3/8" and 1-3/4" Pole Attachment			
LiPo Battery Level Indicator	LiPo 6S with % charge remaining			
Gear Ratio	2.85:1			
Hardened Beveled Gears	60HRc (Surface) / 35HRc (core)			
	Can Use Multiple Units at the same time			
Compatibility	Fits on all tools except hand tools			
CE	CE Compliant			
Die Cast Aluminum	AA380 (Recyclable)			
Die Cast Aluminum Finish	hard anodized			
Charger	LiPo Smart charger with balancer			